

CABBD

for defense



- There are reliability indicators, and the five-level failure rate ($\lambda \leq 1 \times 10^{-5}$).
- 6.3V~450V full voltage series wide operating temperature
- It meets the environmental requirements of vibration, low pressure, humidity resistance and other environmental requirements of the national military standard GJB603-88
- It is suitable for filtering, energy storage and bypass in electronic circuits in aerospace, aviation, alpine, high altitude and ocean
- Main technical parameters:

Item		characteristic						
Operating temperature range		-55°C~+105°C						
Rated voltage range		6.3V~500V						
Nominal capacitance range		1μF~15000μF						
Allowable deviation of nominal capacitance (25°C, 120Hz)		M (±20%)						
DC leakage current (25°C, 5min)		I ≤ 0.02C _R U _R or 3μA (whichever is greater) C _R : Nominal capacitance (μF); U _R : Rated voltage (V)						
The loss angle tangent tgδ (25°C, 120Hz)		U _R (V)	6.3	16~100	160~250	400~500		
		tgδ (≤)	0.20	0.15	0.20	0.20		
		For products with a capacity greater than 1000 μF, the loss tangent increases by 0.02 for each additional 1000 μF.						
Temperature Characteristics (100Hz)	Impedance ratio	U _R (V)	6.3~10	16~35	50~80	100	160~250	400~500
		Z _{-55°C} /Z _{+25°C}	≤4	≤3	≤6	≤5	≤7	≤15
	Rate of change in capacitance	(C _{+25°C} - C _{-55°C}) / C _{+25°C} ≤ 20%						
Durability (High Temperature Test)		The rated voltage is applied at 105°C for 2000h, and after recovery for 24h, the electrical performance of the rated voltage (25°C±5°C) is tested at room temperature.						
		Rate of change in capacitance	≤± 20% of the initial measurement					
		Loss tangent tgδ	≤ 130% of the initial specified value					
		DC leakage current	≤ initial prescriptive value					
Store at high temperatures		After storing at 105°C for 500 hours and recovering for 24 hours, the electrical properties of the two temperatures (25°C±5°C) were tested, and the electrical properties conformed to:						
		Rate of change in capacitance	≤± 10% of the initial measurement					
		Loss tangent tgδ	≤ 115% of the initial specified value					
		DC leakage current	≤ 200% of the initial specified value					

Execution standard number: Q/MN20003—1995 GJB603—88

■ Outline drawing and size table (mm)

D	±0.5			±1.0					
	5	6.3	8	10	12.5	16	18	22	25
F±0.5	2.0	2.5	3.5	5		7.5		10	12.8
d±0.1	0.5		0.5			0.8			

CABBD

for defense

■ List of product specifications and technical parameters

UR(V) CR(μF)	6.3 0J		10 1A		16 1C		25 1E		35 1V		50 1H		63 1J	
	DxL (mm)	I~ (mA)	DxL (mm)	I~ (mA)	DxL (mm)	I~ (mA)	DxL (mm)	I~ (mA)	DxL (mm)	I~ (mA)	DxL (mm)	I~ (mA)	DxL (mm)	I~ (mA)
10													5×11	26
15											5×11	29	6.3×11	36
22									5×11	32	6.3×11	39	6.3×11	43
33							5×11	36	6.3×11	43	6.3×11	47	8×12	61
47					5×11	42	6.3×11	48	6.3×11	52	8×12	66	8×12	73
68			5×11	44	6.3×11	54	6.3×11	58	8×12	72	8×12	79	10×12.5	99
100	5×11	49	6.3×11	58	6.3×11	66	8×12	81	8×12	87	10×16	120	10×20	155
150	6.3×11	66	6.3×11	72	8×12	93	8×12	99	10×12.5	120	10×20	170	10×25	212
220	6.3×11	88	8×12	101	8×12	112	10×12.5	134	10×16	162	12.5×25	230	10×30	252
330	8×12	112	8×12	123	10×12.5	154	10×16	184	10×20	230	12.5×30	309	12.5×30	345
470	10×12.5	150	10×12.5	165	10×16	206	10×20	254	10×30	336	12.5×35	368	12.5×35	488
680	10×16	202	10×16	221	10×20	286	10×30	375	12.5×25	405	12.5×35	525	16×30	627
1000	10×20	283	10×20	310	10×30	425	12.5×25	454	12.5×30	538	16×30	680	16×40	878
1500	10×25	388	10×30	466	12.5×25	521	12.5×30	610	16×35	760	16×40	962	18×40	1050
2200	10×30	494	12.5×25	538	12.5×30	651	16×35	798	16×40	921	18×40	1128		
3300	12.5×25	584	12.5×35	746	16×35	874	16×40	995	18×40	1197				
4700	12.5×35	796	16×30	915	16×40	1074	18×40	1277	22×40	2714				
6800	16×30	962	16×40	1106	18×40	1261	22×40	2586						
10000	16×40	1212	18×40	1352										
15000	18×40	1430												

Rated ripple current
(105°C, 100Hz)

UR(V) CR(μF)	100 2A		160 2C		250 2E	
	DxL(mm)	I~(mA)	DxL(mm)	I~(mA)	DxL(mm)	I~(mA)
4.7					8×12	50
6.8	5×11	41	8×12	52	8×16	62
10	6.3×11	48	8×12	72	10×16	92
15	8×12	60	10×12.5	98	10×20	115
22	10×12.5	70	10×16	135	10×25	150
33	10×16	130	10×20	180	12.5×20	200
47	10×20	145	12.5×20	240	12.5×25	269
68	12.5×20	180	12.5×25	275	16×25	340
100	12.5×25	219	12.5×30	380	16×30	460
150	12.5×30	310	16×25	490	18×30	530
220	12.5×35	365	16×36	700	18×40	760
330	16×30	580	18×35	851	22×50	1010
470	16×40	765	18×45	1080		
680	18×40	955	22×50	1300		
1000	22×50	1150				

Rated ripple current
(105°C, 100Hz)

UR(V) CR(μF)	400 2G		450 2W		500 2H	
	DxL(mm)	I~(mA)	DxL(mm)	I~(mA)	DxL(mm)	I~(mA)
1	8×12	20	8×12	20	10×12	22
1.5	8×12	28	10×12.5	23	10×16	25
2.2	10×12.5	34	10×16	29	10×20	32
3.3	10×16	48	10×16	35	10×25	40
4.7	10×20	57	10×20	45	12.5×20	48
5.6	10×20	68	12.5×20	56	12.5×25	61
6.8	12.5×20	80	12.5×20	65	12.5×25	68
8.2	12.5×20	87	12.5×25	68	12.5×30	72
10	12.5×25	100	12.5×30	77	16×30	78
15	16×25	124	16×25	110	16×35	90
22	16×30	170	16×30	138	16×40	115
33	16×35	239	16×40	190	18×40	140
47	18×35	310	18×40	245	18×45	182
56	18×40	350	18×45	288		
68	22×35	425	22×45	330		
82	22×40	494	25×40	398		
100	25×45	580	25×50	450		

CABBD

for defense

HOW TO MAKE A PART NUMBER

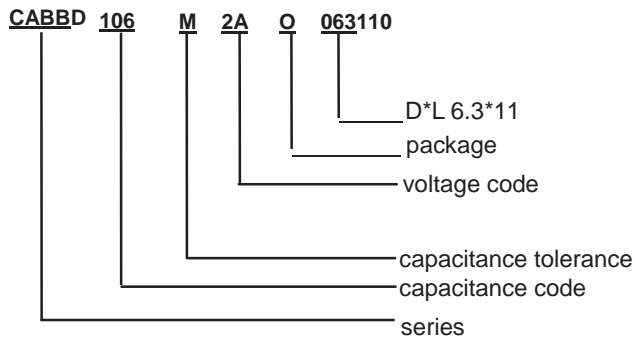

Code	Lead Forming Type
O	Bulk
T	5mm Chip tape
A	(Φ4~Φ6.3)2.5mm tape
F	(Φ4~Φ8)5mm tape
P	Φ≥Φ8mm original(vertical)tape
M	5mm Lead forming
C	C Lead forming
B	B Lead forming
D	(Φ4~Φ8)2.5mm Lead forming