



CBEJ

FEATURES:

- Metal case, Square, Heteropolarity.
- Commingled by Electrolytic Tantalum Capacitor and Electrochemical Capacitor, Small size, Super Capacitance
- Stable in Electrical Performances, High Reliability, Long life-span, Maximum in the Density of Capacitance and Energy
- Built-in as battery in Energy-converted-circuit & Power-pulsed-circuit, functioned as filtering, storage energy, time-delay circuit.

SPECIFICATIONS

Operating Temperature	-55°C to +125°C (to +125°C, with rated voltage derating)
Storage Temperature	-62°C ~ +130°C
Capacitance Tolerance	M: (±20%)



Electrical Characteristics

Rated Voltage (V)	Category Voltage (V)	Surge Voltage (V)	Cap. (µF)	tgδ (%) 100Hz	ESR (Ω) 1kHz	DCL (µA)		Impedance at (Ω) -55°C	Capacitance Change at (%)		Dimensions DxH (mm)
						25°C	85°C, 125°C		-55°C	85°C	
50 1H	30	55	8000	65	0.1	170	1000	1.2	-40	+120	50x38x15 A1
50 1H	30	55	11000	65	0.1	300	2400	1.2	-60	+120	50x38x16 A2

Dimensions (unit: mm)

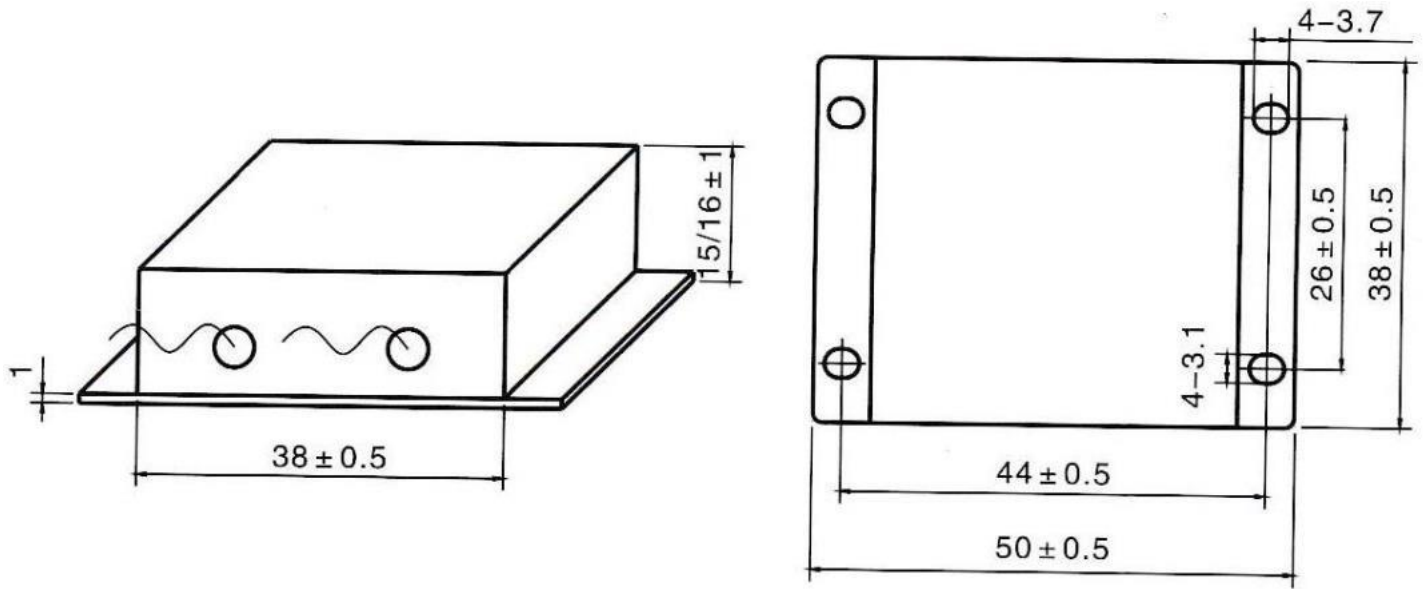

Note:

1. Please do not use multimeter through the measuring procedures (may cause irreversible damage and lead to discard).
2. Capacitance and DF measured at 100Hz, $U_+=2.20^{0.10}V$, $U_- = 1.0^{0.05}V$ Test only applied in series equivalent circuit.
3. Voltage derating is applied at +125°C. (The DCL parameter should be read after 5 minutes when it connected to the circuit).
4. Special size and demand could consult with us.

PART NUMBER EXAMPLE

